

HEAD RACK

INSTALLATION INSTRUCTIONS
2007+ CHEVROLET/GMC FULL SIZE PICKUP

TOOLS REQUIRED: 3/4" WRENCH x 2

PACKAGE CONTENTS

1/2" x 3-1/4" HEX BOLT	X2
1/2" x 1-1/4" HEX BOLT	X2
1/2" x 1-3/4" HEX BOLT	X2
1/2" NUT	X2
1/2" FLAT WASHER	X6
1/2" LOCK WASHER	X6
STAKE POCKET CLIP	X2
MOUNTING BRACKET	X2 (1 LEFT, 1 RIGHT)
BOX SIDE REINFORCEMENT PLATE	X2 (1 LEFT, 1 RIGHT)
OBROUND WASHER	X2
HEAD RACK	X1

STEP 1

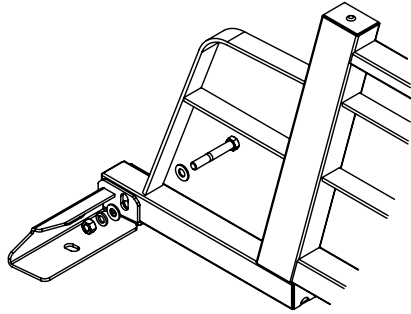

FASTEN EACH MOUNTING BRACKET TO THE HEAD RACK USING ONE 1/2"x3-1/4" HEX BOLT, TWO 1/2" FLAT WASHERS, ONE 1/2" LOCK WASHER AND ONE 1/2" HEX NUT

NOTE: LEAVE ALL FASTENERS FINGER TIGHT TO ALLOW FOR ADJUSTMENT WHEN POSITIONING ON TRUCK.

STEP 2

ATTACH ONE OF THE INCLUDED BOLTS TO ACT AS A HANDLE TO LOWER THE CLIP INTO THE STAKE POCKET. REMOVE THIS BOLT AFTER FASTENING THE CLIP INTO THE STAKE POCKET.

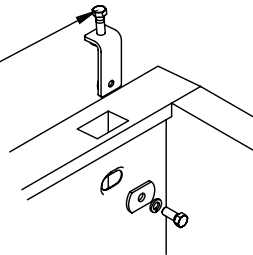

FASTEN CLIP INTO STAKE POCKET AS SHOWN

NOTE: LEAVE ALL FASTENERS FINGER TIGHT TO ALLOW FOR ADJUSTMENT WHEN POSITIONING ON TRUCK.

STEP 3

BOX SIDE REINFORCEMENT PLATE

BOX SIDE RUBBER PROTECTOR

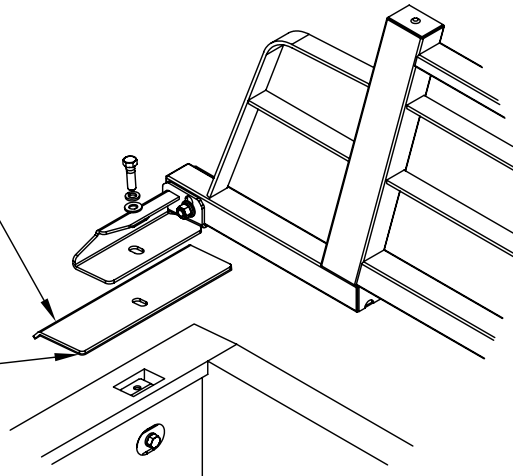

PLACE RUBBER BOX SIDE PROTECTOR, BOX SIDE REINFORCEMENT PLATE AND HEADRACK (WITH BRACKETS) OVER THE FRONT STAKE POCKETS. FASTEN AS SHOWN.

NOTE: ALLOW 1/8" - 1/4" GAP BETWEEN FLANGE ON BOX SIDE REINFORCEMENT PLATE AND OUTSIDE OF BOX (TO PREVENT PAINT SCRATCHES)

STEP 4

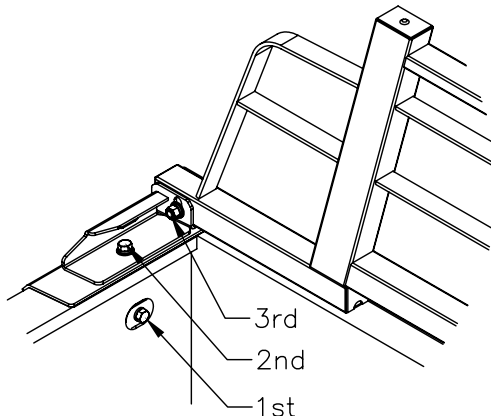

TIGHTEN THE FASTENERS IN THE SEQUENCE SHOWN.